

of an alkaloid in the related species *Eupatorium perfoliatum*. Tests for alkaloids made upon a 5 gramme sample of our material, using Wagner's and Mayer's reagents, gave negative results.

Tannins have been reported in a number of *Eupatorium* species and inasmuch as astringent and haemostatic properties are reported for the recognized matico, it was thought that the presence of tannin in the leaves of *Eupatorium glutinosum*, and their consequent use for similar purposes, might account for the term "Matico" having been applied to them. However, not more than a mere trace of tannin could be detected in an aqueous extract from 25 grammes of the powdered leaves.

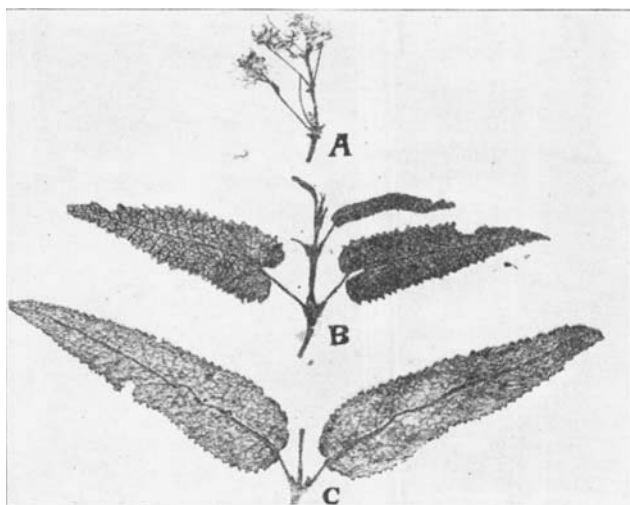

FIG. 1.—EUPATORIUM GLUTINOSUM LAM.

A. Inflorescence; B. Upper surface of leaves; C. Lower surface of leaves.

The taste and flavor of the leaves did not closely resemble those of the recognized matico. A steam distillation showed the presence of about 0.15 percent of a volatile oil resembling in odor that of boneset (*Eupatorium perfoliatum*) of the National Formulary IV (1916). When heated, the oil had a strong odor reminiscent of acetic and a higher fatty acid. It is of interest in this connection that Miller<sup>6</sup> reports the presence of acetic and probably another higher fatty acid in the volatile oil of *Eupatorium capillifolium* (Lam.) Small. Unfortunately, the amount of material available was insufficient to obtain the amount of oil necessary for further work.

#### AN IMPROVED APPARATUS FOR TESTING THE ACTIVITY OF DRUGS ON THE ISOLATED UTERUS.\*

BY PAUL S. PITTENGER.

The importance of biologic assay methods as a means of securing uniformity in the action of drug preparations not amenable to chemical standardization is just beginning to be fully appreciated. The incorporation of a chapter on "Bio-

<sup>6</sup> "A Chemical Study of the Oils of Several Species of *Eupatorium*," E. R. Miller, University of Wisconsin, *Bull.* No. 693, p. 1-41 (1914).

\* Read before the Scientific Section, A. Ph. A., Indianapolis meeting, 1917.

logic Assays" in the present ninth edition of the U. S. P. is an epoch in the history of standardization and it is to be hoped that with this start a much wider publicity and experience will be gained so that the next Committee of Revision will readily be able to select from the proposed methods and make official the methods which prove to be the most satisfactory and convenient for each drug. Many methods used for the biologic standardization of drugs are not new but merely *quantitative* applications of methods used to elucidate the drugs' physiologic action. The principal task of the biologic chemist, therefore, is the selecting of the most suitable method for the particular drug under consideration.

Second in importance to the selection of the most suitable methods for this work is the *selection and improvement of the apparatus* employed. This is particularly true in experiments upon isolated organs where it is necessary to simulate the normal conditions within the animal from which the organ has been excised. Very often the importance of details of apparatus employed has been lost sight of and only too frequently have papers been written criticizing or condemning methods because concordant results could not be obtained when in fact the principal cause of the non-concordant results was not a faulty method but a *variation in the apparatus employed or in the inexperience of the operator*.

Frequently one operator will read an article on the assay of a particular drug or preparation in which the author of the paper gives detailed descriptions of the apparatus as well as the method employed and without going to the necessary expense and labor of duplicating the author's apparatus will carry out the test suggested on the nearest "thing" which happens to be in the laboratory. After a possible eight or ten experiments a marked variation is found in the results obtained and a paper is written criticizing the original method when in fact due to the difference in apparatus employed the experimenter has never really carried out the original method or performed enough experiments to become sufficiently experienced to pass an opinion upon the subject.

The above comments particularly apply to apparatus employed in making tests upon the isolated uterus. For example, the author in two different papers<sup>1</sup> as well as in his text-book on *Biochemic Drug Assay Methods* describes in detail and recommends an apparatus and method for making *quantitative* determinations of the action of drugs on the isolated uterus. These articles all state that the particular advantage of the apparatus described lies in the fact that the interference with the test produced by spontaneous contractions and increased sensitiveness of the uterus are practically overcome by replacing the Harvard light muscle lever, which was generally employed for recording uterine contractions, by an *escapement wheel and stylet* and the use of the *entire one horn* of the uterus in place of a segment; the free end of the uterus to be attached by means of a silk thread to one side of the wheel while from the other side is suspended a counterpoise bucket for holding shot. It was further explained that "By adding the proper amount of shot to this bucket the operator is enabled to weight the uterus down and thus reduce the amplitude of the spontaneous movements so they can

---

<sup>1</sup> "The Application of Some Muscular Tissues Adapted to Physiological Standardization." *Monthly Cyclopedia and Medical Bulletin*, Sept. 1913.

"A New Uterus-Contracting Method of Testing Ergot, with Comparison with the Blood-Pressure Method." *JOURNAL A. PH. A.*, July 1914.

be controlled. Thus, the marked spontaneous contractions can be reduced until the uterus is just able to contract under the increased load or, in other words, shot is added until the maximum amount of work that the uterus is normally capable of performing is counterbalanced. Any increase in the amplitude of the contraction after the addition of a given drug can now be produced only by that drug." It was also suggested that the uterus be suspended in a cylinder containing about 250 mils of Loche's solution.<sup>2</sup>

Several workers later claimed that Pituitary Extract could not be satisfactorily assayed by the uterine method because of marked spontaneous contractions present normally in many uteri and of the increased sensitiveness after a few doses of the drug. After an investigation the writer discovered that the authors of these criticisms had employed the "old style" isolated uterus apparatus consisting of a Harvard light muscle lever and a muscle warmer of about 40 mil capacity when the link between success and failure in carrying out *quantitative* tests upon the isolated uterus lies in the use of an *escapement wheel and bucket* for shot and the suspension of the entire one horn of the uterus in a relatively large quantity of Loche's solution preferably about 250 mils.

The above comments are made before describing the apparatus which forms the subject of this paper in order to bring out the point that in biologic assays where the most accurate *quantitative* results are desired it is just as essential to pay attention to details and strive to improve the apparatus as it is to improve the methods themselves. The form of apparatus recommended for a particular test is as much a part of the method as the animal employed.

Fortunately, in the majority of cases the foregoing statements do not apply to workers who have given the subject serious thought and have devoted a considerable amount of time to practical experimental and research work, in an endeavor to improve and determine the limitations of the various methods proposed, but to those who devote practically all of their time to allied subjects and merely dabble in biologic standardization.

The former all agree that wonderful strides have been made within the last few years and that the value of physiologic standardization as a means of securing *uniformity* in the strength of drugs and their preparations can not be over-estimated. The importance of this work is admirably set forth by Vanderkleed<sup>3</sup> in the following words:

"Is it after all so necessary, so important, that preparations of digitalis, ergot, pituitary, etc., be standardized? In answer to that I would only say that we must all agree that it is the duty of our profession to render the best service to humanity of which we are capable. Now if we did not know that preparations of potent drugs like digitalis, strophanthus, ergot, etc., vary hundreds of percent in activity, when prepared indiscriminately and without physiologic control, we might be justified in continuing to market such variable products with the hope that after all the physician will be able to feel his way—and in many cases succeed in hitting the bull's eye, even with the handicap of poor weapons. But now that, thanks to pharmacodynamic investigation, we do know that digitalis tinctures or ergot fluidextracts may, and often do, without such control, vary

<sup>2</sup> "Biochemic Drug Assay Methods," pages 73 to 82.

<sup>3</sup> "Physiologically Standardized Pharmaceuticals," by C. E. Vanderkleed, read before Ohio Pharmaceutical Association, July 1916.

all the way from practical inactivity to several times the normal strength, I personally feel that I could never conscientiously send out any such preparations unless I knew it had been physiologically tested and standardized."

It is gratifying to note that practically all objections made to physiologic assay methods are of the same general order, *i. e.*:

"Is the sample of drug that has been found to possess the greatest power to kill a cat the one that will prove the most efficient in curing a man?"

"Is the physiologic effect of the drug that is measured the one that gives it its therapeutic value?"

"The result of the assay depends upon *toxic* effects."

"The animal chosen is biologically much different than man."

"How can we calculate from the amount of drug necessary to produce a certain effect upon a dog how much will be required to produce the same effect upon man?"

The above questions clearly indicate a lack of conception on the part of these critics of the real purpose of the physiologic test, namely, to secure *uniformity*. The determination of the real value of a drug in the treatment of disease in man is another matter entirely. It is not the object of Biologic Standardization to attempt to show from the effect of a certain drug upon the cat how it will act upon man; or to calculate from the amount of drug necessary to produce a certain effect upon the dog how much will be required to produce the same effect upon man; or from the amount necessary to kill a guinea-pig how much will kill a man. These are all questions which concern the experimental physiologist and not the physiologic assayer except indirectly. Biologic assays are recommended in the U. S. P. IX only for drugs of *well-known physiologic effect and therapeutic efficiency*. It is not the object, therefore, to attempt from the results of our experiments on cats or dogs to tell the practitioner how these drugs will act on man because he knows the effects of these drugs from the results of thousands of clinical tests *on man*. Neither is it the intent to tell the practitioner how much tincture of digitalis, for example, will be required to produce a certain effect on man from the amount which produces the same effect on frogs or guinea-pigs because the practitioner's experience has taught him the proper dosage of these well-known drugs. As before stated, the sole object of biologic assaying is to devise and perfect methods whereby it is possible to produce *uniform* preparations. Therefore, if we always adjust a preparation to the same strength upon the same animal it will always produce the same effect upon man regardless of the relation between the two. Obviously, however, some more or less definite ratio must be shown to exist between the result obtained from the physiologic test and the therapeutic activity of the preparation, but to claim that because a frog is not comparable to a man, it should not be employed in physiologic testing, is as illogical as to deny that a chemical assay is of value because a chemical balance and a set of weights are not related to the human circulatory system.

To return to the subject of the paper, the author in his text-book and two papers previously mentioned describes in detail an apparatus and method for testing the activity of drugs upon the isolated uterus. A brief description of this apparatus follows:

The uterus is suspended in about 250 mls of Loche's solution contained in a cylindrical glass vessel (*G*) (Figure 1), the lower end of which is plugged with a rubber stopper (*O*) having a central bore. Through the latter passes one arm of a

wide glass "T" tube (*J*) which ends flush with the upper surface of the stopper, so that the cylindrical vessel may be completely emptied. This tube passes through a second rubber stopper (*L*) which fills an opening in the bottom of an outer metallic vessel (*F*) which forms a constant temperature water jacket.

The temperature of the water in the jacket is kept constant by means of a metallic rod (*E*) which penetrates the wall of the jacket, passes through the water, and is soldered to the opposite side of the jacket. The portion of the rod external to the jacket is heated by a protected Bunsen burner (*C*) which slides on the rod. The temperature is regulated by sliding this burner backward and forward until that point is reached where the amount of heat transmitted by the rod to the water inside is sufficient to keep the thermometer (*T*) suspended in the water at the proper degree ( $38^{\circ}$  to  $39^{\circ}$  C.).

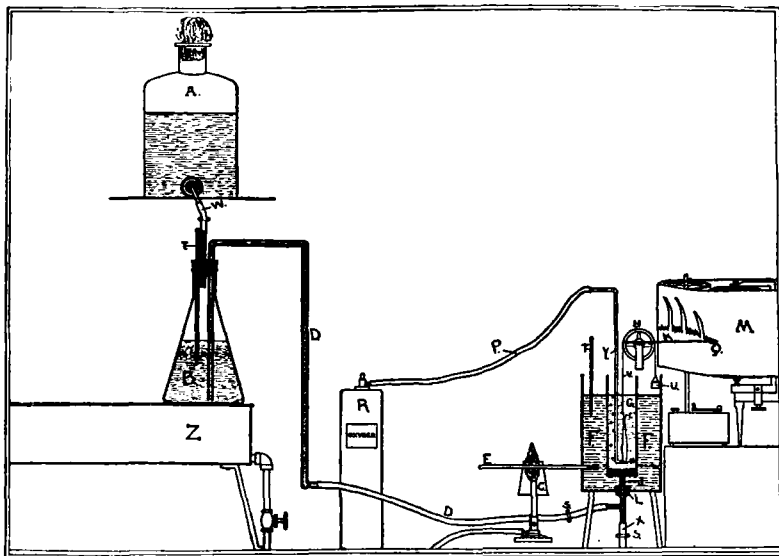

FIGURE 1.—A graphic drawing of the original apparatus and will serve to illustrate the description given in text.—From Pittenger's "Biochemic Drug Assay Methods."

One of the other arms of the "T" tube is connected by a rubber junction (*X*) armed with spring clamps (*S*) to a waste pipe by which the cylindrical glass vessel may be emptied.

The remaining arm is connected by a syphon tube (*D*) to a flask (*B*) which holds a small amount of Loche's solution for refilling the cylindrical vessel. This flask is kept at a temperature between  $40^{\circ}$  and  $45^{\circ}$  C. by means of a steam bath (*Z*). The main supply of Loche's solution is contained in a large aspirator bottle (*A*) connected with the small flask by a rubber tube (*W*), the object being to avoid exposing the reserved solution to prolonged heat. Heat causes Loche's solution to gradually decompose and lose  $\text{CO}_2$ .

The Loche's solution in the small flask should be reduced to  $39^{\circ}$  C. immediately before admitting it to the cylindrical vessel by allowing sufficient cold solution to run into it from the aspirator bottle.

Into the cylindrical vessel containing the Loche's solution dips a narrow glass tube (*Y*). This tube is turned at right angles about half an inch from its lower end. Into this is sealed a platinum pin (*N*) for attaching the lower end of the isolated uterus. The upper end of this tube is connected by means of rubber tubing (*P*) to an oxygen reservoir (*R*). A constant stream of oxygen is allowed to bubble through a small vent at the lower end of the tube, thus preserving the muscular irritability of the uterus and at the same time stirring the Loche's solution.

The other end of the uterus is fastened to a small platinum hook (*I*) connected to a silk thread (*V*) which passes over an escapement wheel (*H*) and is attached to a pin on the opposite side of the wheel. A counterpoise bucket for holding shot (*U*) is attached to the opposite side of the wheel. To this wheel is soldered a stylet of aluminum (*K*), the axle of the wheel serving as a fulcrum. To the end of this stylet a pen point is fixed (*Q*) for recording the contractions of the uterus on the revolving drum of the kymograph.

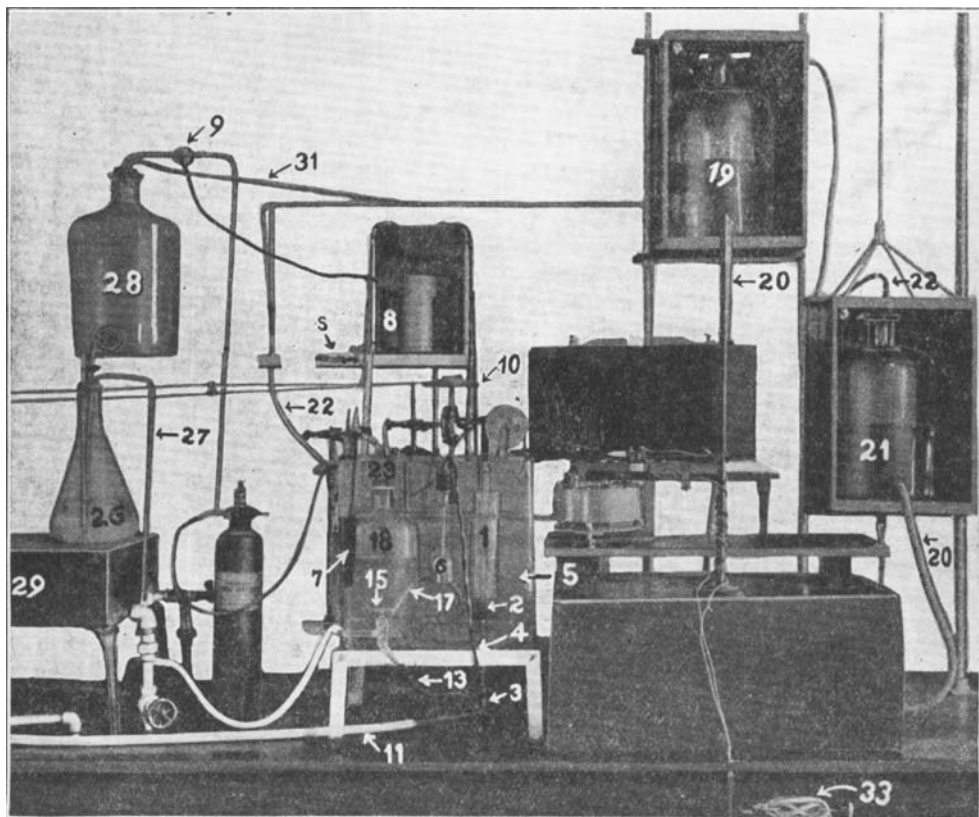

FIGURE 2.—Improved apparatus for testing the activity of drugs upon the isolated uterus.

This apparatus was in continuous use in the laboratory for two and a half years and gave very satisfactory results in testing Ergot and Pituitary Extracts. During this time, however, its limitations were carefully studied with the result that several details were noted in which marked improvements could be made.

*First.* The uterus was subjected to more or less shock at times due to the fact that it was impossible to always have the temperature of the Loche's solution in *B* at exactly 38° C. the instant it was necessary to use the same for refilling *G*. It was thought advisable, therefore, to make the constant temperature bath *F* of sufficient capacity to accommodate the bottle containing the warm Loche's solution for refilling *G*. With this stock solution in the same water bath as the cylinder containing the uterus it must necessarily be of the same temperature and thus produce no shock to the uterus when the drugged solution is run off and fresh solution run in.

*Second.* The metal tank was replaced by glass which enables the operator to observe to a better advantage the rate at which the oxygen is flowing, the amount of solution in stock bottle and the temperature of the bath.

*Third.* The brass rod and bunsen burner for heating the water in bath was replaced by an electric immersion heater, the temperature of the water being automatically regulated by means of a toluol-mercury thermostat or an Eberbach Bimetallic electric thermo-regulator.

*Fourth.* The escapement wheel was improved so that the writing point can be raised or lowered without destroying the tension on the uterus or changing the clamps on the stand.

*Fifth.* An elevator was added to accommodate two aspirator bottles of water for furnishing air pressure to force the Loche's solution from the stock bottle into the cylinder containing the uterus.

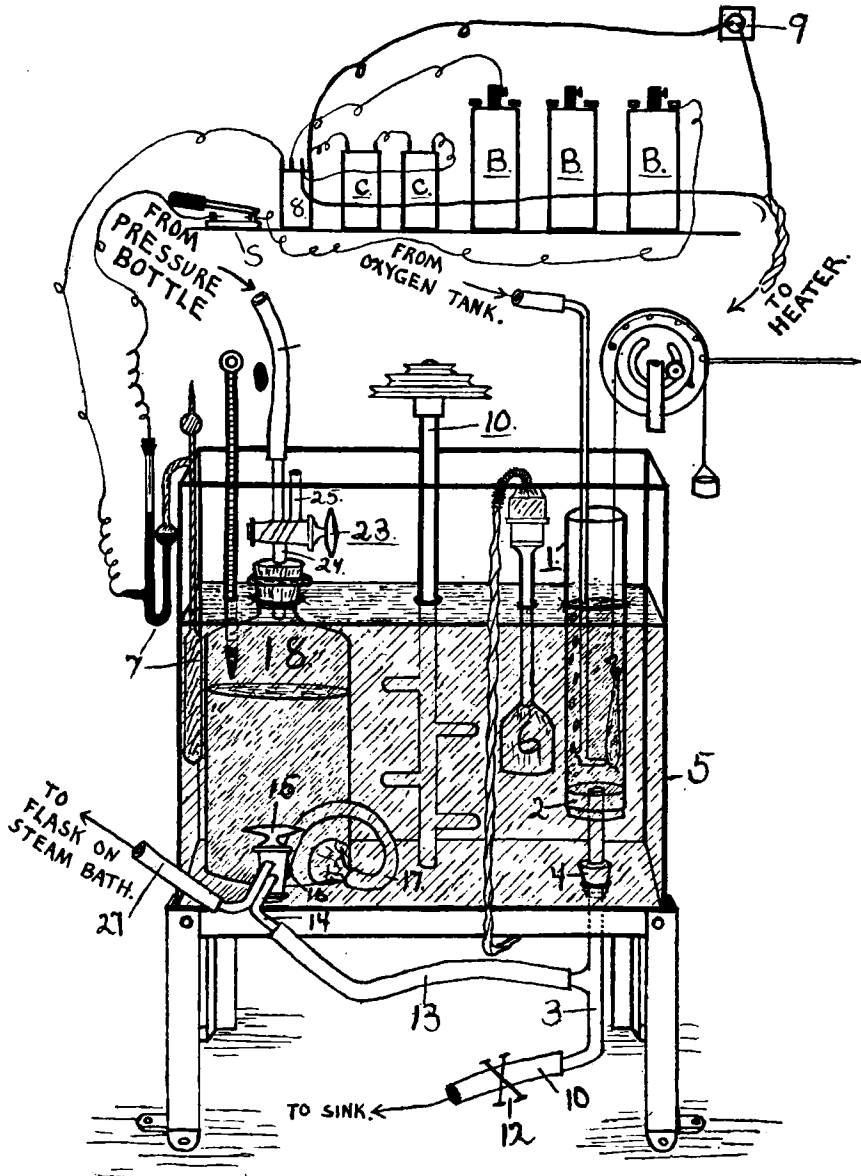

FIGURE 3.—Graphic drawing showing the arrangement of apparatus within the constant temperature bath and method of connecting batteries (B), condensers (C) and relay (8) with the thermo-regulator (7) and heater (6).

The complete improved apparatus is shown in Figure 2. Figure 3 is a graphic drawing showing the arrangement of the stock bottle, thermostat, heater, cylin-

drical vessel and stirrer, within the constant temperature bath. The labeling of corresponding parts is the same in both figures and will serve to illustrate the following detailed description:

The uterus is suspended in about 250 mls of Loche's solution contained in a cylindrical vessel (1), the lower end of which is plugged with a rubber stopper (2) having a central bore. Through the latter passes one arm of a wide glass "T" tube (3) which ends flush with the upper surface of the stopper, so that the cylindrical vessel may be completely emptied. This tube passes through a second rubber stopper (4) which fills an opening in the bottom of the outer glass vessel (5) which, when filled with water, forms a constant temperature water bath.

The water in the bath is heated by means of a "Universal" electric immersion heater (6). The temperature of the water is automatically kept at 38° C. by means of a toluol-mercury regulator (7) which makes and breaks the circuit from the batteries (B) to the relay (8) which in turn makes and breaks the electric current (110 or 220 volt) from plug (9) to the heater. The heat is evenly distributed throughout the water by the stirrer (10) which is driven by a small water or electric motor. The condensers (C) are used to prevent sparking when the relay (8) makes and breaks the electric current and thus prevents the contacts from burning off. For a 110-volt circuit only one condenser is necessary.

One of the other arms of the "T" tube is connected by a rubber junction (11) armed with a spring clamp (12) to a waste pipe by which the cylindrical glass vessel may be emptied.

The remaining arm is connected by rubber tubing (13) to one branch (14) of a "3-way" stopcock (15). One of the other branches of the stopcock passes through a rubber stopper (16) which fills an opening in the side of the glass water jacket. The end of this branch projects on the inside of the water jacket and is connected by means of a rubber tube (17) to the outlet of aspirator bottle (18) which contains unmedicated Loche's solution. Therefore, when the stopcock is turned to the proper position the unmedicated solution from the aspirator bottle (18) is forced through the connections just described by air pressure into the cylindrical vessel (1) containing the uterus.

The air pressure is supplied by allowing water to flow from an elevated aspirator bottle (19) through rubber tubing (20) into lower aspirator bottle (21). The air thus compressed above the liquid in the lower aspirator bottle is lead by means of pressure tubing (22) to the one branch of a "3-way" stopcock (23). One of the other arms of the stopcock (24) passes through a rubber stopper which tightly fits into the neck of the aspirator bottle (18) containing the Loche's solution. The remaining arm (25) of stopcock (23) permits air to escape when aspirator bottle (18) is refilled from flask (26) on steam-bath by means of siphon tube (27).

It will be noted, therefore, that when stopcocks numbers (15) and (23) are turned to the proper position the air pressure passes through stopcock (23) and forces Loche's solution from bottle (18) through tubing (17), stopcock (15) and tubing (13) to cylindrical glass vessel (1) containing the uterus. When the two stopcocks are turned in the opposite direction the Loche's solution in flask (26) siphons through tubing (27), stopcock (15) and tubing (17) and refills bottle (18) while the air in (18) escapes through stopcock (23).

The flask on the steam bath (29) is kept at a temperature between 40 and 45° C. A supply of Loche's solution is kept in the large aspirator bottle (28) connected with the flask by a rubber tube armed with a screw clamp, the object being to avoid exposing the reserved solution to prolonged heat. The Loche's solution in the flask is reduced to approximately 39° C. before siphoning into bottle (18) where the water bath adjusts it to exactly 39° C.

The neck of the large aspirator bottle is closed by a tight-fitting rubber stopper, through which pass two glass tubes. The one tube (30) is connected with a 20,000 mil bottle underneath the table which contains the reserve sterile Loche's



solution while the other (31) is connected with a water vacuum pump. Thus, by merely turning on the water to the pump the large aspirator bottle (28) is refilled with the sterile solution from the reserve bottle underneath the table without exposing the same to the air.

The method of suspending the uterus, supplying the oxygen and recording the contraction, are the same as with the original apparatus (see page 515) except that a marked improvement has been made in the construction of the escapement wheel.

It often happens that after suspending a uterus in the oxygenated Loche's solution it will relax to a greater extent than was expected by the operator and the writing point will fall below the smoked paper. Occasionally a uterus will make apparently normal contractions and react readily to the drug, but after two or three doses will suddenly relax to a much greater extent and establish a new normal far below the original. It is not convenient to lower the paper on the double drum kymograph to bring the writing point into proper position.

In the above cases it was necessary, therefore, with the original apparatus, to either shorten the thread which attaches the uterus to the wheel or to lower the tube to which the lower end of the uterus is attached. Both of these methods destroy the tension on the uterus and spoil the tracing.

The wheel on the improved apparatus consists of two parts (*A* and *B*, Figure 4). (*A*) is soldered to the axle while (*B*) is free and may be rotated independent of the axle. The stylet and writing pen are also soldered to (*A*). In (*B*) there is a

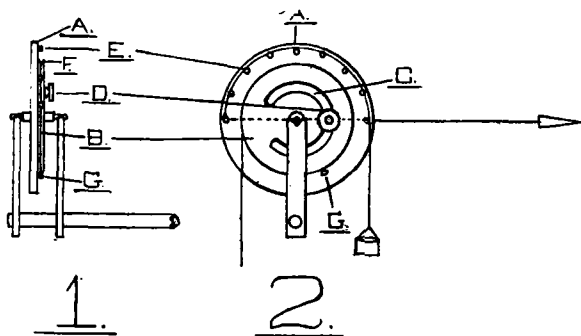

FIGURE 4.—Shows the construction of the improved escapement wheel. 1. Side view. 2. Front view.

crescent-shaped perforation (*C*) through which passes a small rod. The one end of this rod is soldered to (*A*) while the other end is threaded and supplied with a thumb nut (*D*) which when tightened acts as a set screw and holds *B* in any desired position. *A* is also supplied with a series of small pegs (*E*) which support the thread holding the bucket for shot. The rim of (*B*) contains a small groove (*F*) in which the thread from the uterus passes around the wheel. The end of this thread is fastened to a small peg (*G*).

This construction makes it possible, by simply loosening the thumb screw and holding (*B*), to rotate (*A*) and thus raise or lower the writing pen without moving (*B*) or disturbing the tension on the uterus. After adjusting the pen to the desired position the thumb screw is tightened and the wheel again acts as if it were constructed of but one piece.

Figure 5 shows the construction of the toluol-mercury thermostat. That portion of the glass tube which is lightly shaded represents toluol (*r*) and the black

portion (2) represents mercury. The platinum point of battery wire (6) is so arranged that it may be raised or lowered through stopper (9) and is connected directly with the zinc pole of the dry batteries. The platinum end of battery wire (5) is constantly in contact with the mercury and the other end is connected to one "battery pole" of the relay. The other "battery pole" of the relay is connected with the carbon pole of the batteries thus completing the circuit when the relay is closed. The relay must be of the type which breaks a contact when the battery circuit is closed by the thermostat and makes the contact when the battery is broken. The switch (S) in Figure 3 is to disconnect thermostat when not in use in order to save batteries.

In order to adjust the thermostat so that it will throw the relay at a given temperature, say, for example, 39° C., it is only necessary to place the bulb (1) in the water bath, bring the temperature of the water to exactly 39° C. and adjust battery wire (6) so that it merely touches the surface of the mercury. After connecting with the relay, condensers and batteries, this apparatus will then automatically keep the water in the bath at a uniform temperature of 38.5 to 39° C. as follows:

Arrange the apparatus as shown in Figure 3; regulate thermostat as already outlined under Figure 5; start stirrer (10); close switch (S) and insert plug (9) in socket.

The heater produces a gradual increase in the temperature of the water which causes the toluol in the thermostat to expand and the mercury to rise. When the temperature of the water reaches exactly 39° C. the mercury touches the platinum point of wire (6), which completes the battery circuit and allows the current from the batteries to run through the coil of the relay, thus forming an electro magnet which lifts the armature of the relay and in turn breaks the contact which stops the strong current from passing to the heater from socket (9).

With the gradual lowering of the temperature of the water the Toluol contracts and causes the mercury to fall away from the platinum wire (6), thus breaking the battery current which is passing through the relay. This break allows the armature of the relay to fall away from the magnet and make the contact which allows the strong current to again pass from the socket to the heater. The heater gradually increases the temperature of the water until at 22° C. the mercury in the thermostat again makes a contact and the whole operation repeats itself. The toluol-mercury regulator, relay and batteries may be replaced, if desired, by an Eberbach bimetallic electric thermo-regulator.

The aspirator bottles (19 and 21) for furnishing air pressure are of eight-liter capacity and are placed in the small boxes which form the carriages of the elevator which may be raised or lowered by means of a rope passing over pulleys

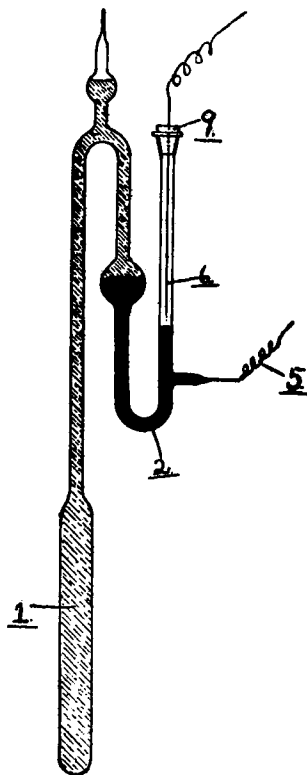

FIGURE 5

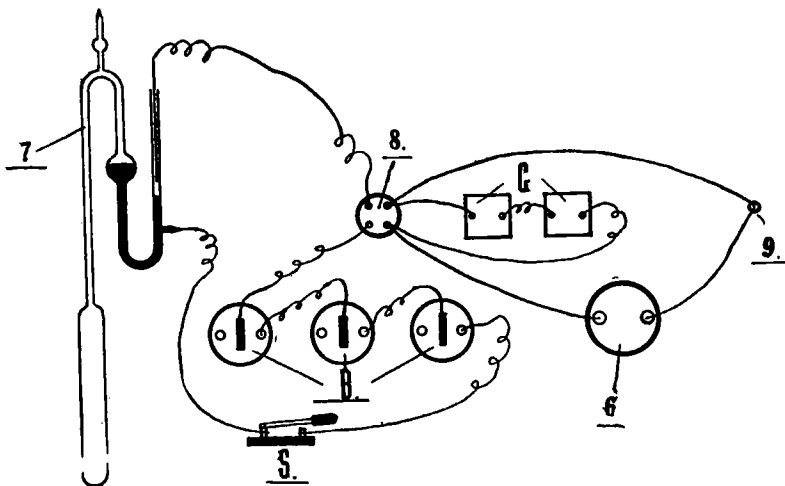

FIGURE 6.—Shows method of connecting thermostat (7); relay (8); condensers (C); batteries (B); switch (S) and heater (6) with the electric plug (9).

underneath the table to an awning cleat (Figure 2, 33) which serves to hold the elevators at any desired position. The method of connecting these bottles and carrying the air pressure to the small aspirator bottle in the water bath is shown by Figure 7.

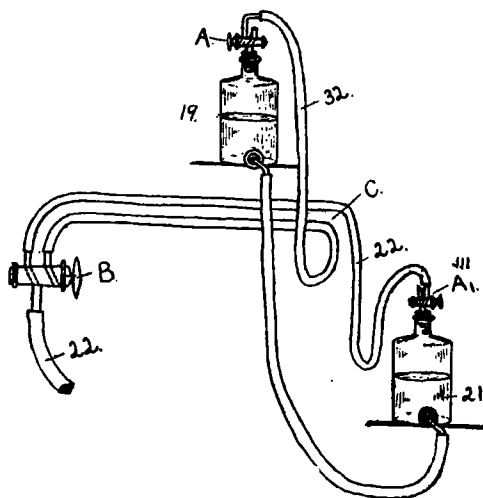

FIGURE 7.—Shows method of connecting aspirator bottles for making air pressure.

It will be noted that each bottle is closed by a rubber stopper containing two holes. One hole of each stopper is fitted with a glass stopcock (A and A-1) while through the other hole of each stopper passes a glass tube which in turn is attached to rubber pressure tubing (22 and 32) leading to two arms of a "three-way" stopcock (B). The other arm of the stopcock is connected by pressure tubing (Figs. 2, 3 and 7, 22) with the small aspirator bottle in the water bath.

The pressure tubes (22) and (32) are fastened to the wall at a point (C) midway between the upper and lower bottle and are of sufficient length to permit the free movement of the bottles from the upper to the lower position.

With the above arrangement the stoppers may be "wired in" and when all the water has passed from the upper to the lower bottle it is only necessary to reverse the position of the two bottles and the three stopcocks. The stopcock in the upper bottle should be open and the one in the lower bottle should be closed. The "three-way" cock should be turned so that the tubing (22) is in direct connection with the air pressure in the lower bottle. With the old method in which the neck of the lower bottle alone is supplied with a stopper and tubing it was necessary to change the stopper and tubing from one bottle to the other each time the positions of the bottles were reversed.

In conclusion, I would state that when an *escapement wheel and counterpoise bucket*, as described in Figure 4, is employed and the *entire one horn* of the uterus is used much more active quantitative results are obtained than when only a slender segment is taken and attached to a light heart lever.

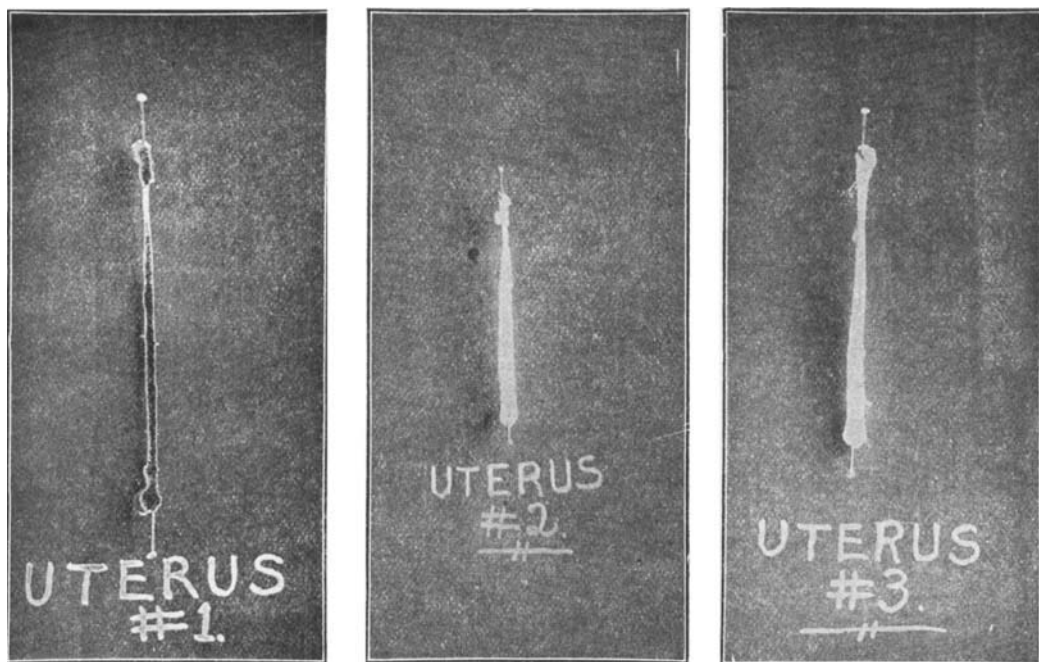

FIGURE 8.—Illustrates the variation in muscular structure in different uteri. The above uteri were all taken from guinea-pigs weighing from 280 to 320 grams.—From Pittenger's "Biochemie Drug Assay Methods."

Only sensitive uteri, however, should be employed as different uteri vary greatly in their mutual relation and to power and muscular structure (see Figure 8). Some specimens are greatly deficient in muscular substance and act feebly while other specimens show greater muscular development and contract strongly. Some specimens prove absolutely inert and will not respond at all. The normal activity, however, practically runs parallel with the amount of muscular tissue present; the "stringy" uteri like No. 1 (Figure 8) are all deficient in normal ac-

tivity and in response to stimuli, while the thick, more muscular uteri are practically all active and sensitive. This knowledge enables the operator to save considerable amounts of time, as it renders it possible for him to distinguish between active and inactive uteri before connecting them with the apparatus.

PHARMACODYNAMIC LABORATORY,  
H. K. MULFORD COMPANY,  
AUGUST 1, 1917.

---

## WATER DROPS AND WATER DROPLETS.

BY A. B. LYONS.

There has been much discussion regarding a standard dropper for accurate measuring of small quantities of fluid. It has been shown that the size of the drop depends—other things being equal—on the diameter of the delivery tube at its orifice, and that when that diameter is 3 millimeters the dropper will deliver at standard temperature 20 drops of distilled water to the mil.

Obviously the usefulness of such a dropper would be very limited, since for different liquids, including aqueous solutions of different substances, the count of the drops per mil varies greatly. We have indeed occasion often in the laboratory to measure small quantities of a liquid by drops, but for such purpose we use an ordinary pipette, ascertaining by experiment how many drops per mil it will deliver of the particular liquid we propose to measure with it. Even so, we make our measurement only from the middle third of the pipette, or from the enlarged portion of the same.

In the use of such extemporized standard droppers we have been accustomed to keep in mind the effect of temperature on the size of the drops, using them only at temperatures not more than 5 degrees centigrade above or below that at which the dropper was standardized. Inasmuch, however, as the quantities measured in this way are never large, the effect of temperature, even in cases where the coefficient of expansion is large, is almost negligible as long as measurements are made at room temperature.

There is, on the other hand, an important possible cause of variation in the size of drops delivered from a pipette or dropper which has been very generally overlooked. This is *the character of the atmosphere in which the drop is formed*. The important factors governing the size (*i. e.*, the weight) of the drop are the surface tension of the fluid and the attraction between the fluid and the surface with which it is in contact. The first of these factors may be influenced enormously by the presence in the atmosphere of certain gases or vapors.

A few simple experiments will illustrate. Deliver into an empty flask from a pipette a certain volume of water, measured by the interval between two fixed lines on the pipette, counting the drops. Now put into the flask a little ether and repeat the count. The number of drops will be more than twice as great as in the first experiment. If the flask contains some strong alcohol the number of drops will be 25 or 30 percent greater than when it is empty, or contains only water. You are no longer getting standard drops, although the pipette is delivering the same fluid as before—contaminated at most with no more than a trace